

# **Bumpstead Hall Farm, Helions Bumpstead, Essex: archaeological record**



**report prepared by  
Leigh Alston MA**

**commissioned by  
Robert Crawford Associates**

NGR: TL 66266 41202  
Site code: HBBH 07



**Colchester Archaeological Trust**  
12 Lexden Road,  
Colchester,  
Essex CO3 3NF

*tel.:* (01206) 541051  
(01206) 500124  
*email:* [archaeologists@catuk.org](mailto:archaeologists@catuk.org)

**CAT Report 443**  
October 2007

## Contents

<b>1 Introduction</b>	1
<b>2 Summary</b>	1
<b>3 Documentary and cartographic survey</b>	2
Illus 1: MS Map of 1812 (ERO D/DQ 1/1).	
Illus 2: Tithe Map of 1841 (ERO D/CT 380).	
Illus 3: MS Estate Survey of c 1887 (in possession of current owners).	
Illus 4: First Edition 25-inch Ordnance Survey, 1877.	
Illus 5: Second Edition 25-inch Ordnance Survey, 1897.	
Illus 6: Third (new) Edition 25-inch Ordnance Survey, 1921.	
<b>4 Descriptive record</b>	7
Fig 1 Block plan of site.	
Block 1: 16th-century barn	
Block 2: 17th-century barn	
Block 3: 20th-century shelter shed (eastern)	
Block 4: 20th-century shelter shed (western)	
Block 5: 20th-century pig yard	
Blocks 6 and 7: mid 19th-century brick cart-lodge	
Blocks 8 and 9: mid 19th-century brick sheds	
<b>5 Frame survey for barns 1 and 2</b>	15
Fig 2 Barn 1: ground-plan.	
Fig 3 Barn 1: southern and northern internal elevations V-Q and K-P.	
Fig 4 Barn 1: open truss R-L with internal elevation M-W of porch.	
Fig 5 Barn 1: internal elevation of western gable Q-K.	
Fig 6 Barn 2: ground-plan.	
Fig 7 Barn 2: internal elevation of northern wall A-E.	
Fig 8 Barn 2: internal elevation of southern wall J-F.	
Fig 9 Barn 2: open truss H-C from east.	
Fig 10 Barn 2: Internal elevation of eastern gable E-J.	
Fig 11 Barn 2: detail of arcade plate scarf joint.	
Fig 12 Barn 2: similar scarf illustrated by Hewett ( <i>English Historic Carpentry</i> ).	
<b>6 Appendices</b>	26
Appendix 1: selected photographs	
Appendix 2: list of full photographic record (images on CD)	38
Summary sheet	42



*This report provides a written and photographic record at English Heritage (2006) Level 3 of a complex of former farm buildings that includes a grade II listed aisled barn. It is intended to fulfil a condition of planning permission for domestic conversion and has been prepared to a brief designed by the Historic Environment Management team of Essex County Council (September 2006) and an associated Written Scheme of Investigation (CAT, September 2007).*

## **1 Introduction**

The following written report is accompanied by a CD containing a full photographic record in the form of 8.2 megapixel digital images (Appendix 2), but also includes 24 prints of key features (Appendix 1). Each image is separately described in the written report. The buildings were surveyed during October 2007 when the accompanying photographs were taken. Wherever practical, a white metre rod with centimetre subdivisions was included for scale purposes.

## **2 Summary**

Bumpstead Hall occupies the site of a medieval manor of the same name, otherwise known as Earls Bumpstead, which was held by Wulfwin before 1066 and by the de Vere Earls of Oxford from the Conquest until its sale in 1580 to the Stubbing family. The present farmhouse was much altered during the mid 19th century, but preserves a well-framed mid to late 15th-century jettied parlour cross-wing and a 16th-century floored hall.

Of the several farm buildings shown on maps of 1812 and 1841, only two substantial barns survived a major mid 19th-century reconstruction which saw the addition of various cattle yards, shelters and sheds to the south of the barns and a range of brick sheds to the north. A second major refurbishment of the early 20th century saw the demolition of almost all the mid 19th-century buildings to the south and their replacement with a new stable and a pair of open-sided shelter sheds. The 20th-century shelters still survive, and preserve good boarded cattle mangers and hay-racks, but the stable was demolished after the storm of 1987. The northern brick sheds of the mid 19th century still remain, albeit much altered, as does an unusually large enclosure of early 20th-century pig-sties. In the light of the 20th-century demolitions, the ancillary farm buildings are not of particular historic significance when compared with others in the region.

The two timber-framed and weather-boarded barns remain fine examples of the early 16th and early 17th centuries respectively, despite extensive reconstruction and the replacement of both roofs in the early 20th century. The western barn (barn 1) is the older of the two and was a particularly expensive and ostentatious structure when first built, but its merits are now less obvious than those of its neighbour and it is not listed (despite the retention of its original tie-beam braces). This barn extended to 24.2 m in length by 7.5 in width (79 feet 6 inches by 24 feet 6 inches) and contained five bays with a central southern entrance, although a secondary porch of the late 17th century now projects to the north. Each of the four outer bays contains an unusual intermediate post, and the original roof, now lost, was of crown-post construction. A lean-to addition to the north can probably be dated to 1801 by an inscription on an associated storey post. This building remains a fine late-medieval barn of considerable structural and historic interest that pre-dates the sale of the property by the Earls of Oxford.

The later of the two barns (barn 2) lies to the east of the site and dates from the early 17th century, although its grade II listing wrongly ascribes it to the 16th century. This building consists of four aisled bays and extends to 18.5 m in overall length by 9.4 m in width (60 feet 9 inches by 31 feet). There is evidence of an original southern entrance in the penultimate western bay. Like barn 1, its roof (originally of side-purlin construction) and many of its wall studs were replaced at the beginning of the 20th century; the height of its external walls was also raised,

thereby completely transforming its external appearance. The framing of the original walls consists largely of re-used timbers that are of interest in themselves as many derive from an early 14th-century aisled structure which possessed lap joints and passing braces, although it is now impossible to reconstruct its precise form. The barn is almost identical to a slightly smaller example at Wiggens Green in the same parish, less than a mile to the north across open countryside. This barn, known as Wiggons Barn, retains its original clasped-purlin roof, complete with cranked wind braces, and its sill beams, but has already been converted for domestic use. Both structures are likely to be the work of the same carpenter as they employ an unusual scarf joint which represents a hybrid between the new 'face-halved-and-bladed' form of the 17th century and the 'edge-halved-and-bridled' standard of the 16th. The scarf at Wiggons was noted by Cecil Hewitt in *English historic carpentry* (1980) and the parallel is mentioned in the listing of barn 2, although the joints differ from Cecil's illustration and are not of the form stated in the list description.

### 3 Documental and cartographic survey

Bumpstead Hall lies on the lower slope of a shallow valley in arable countryside approximately 1.2 km south-east of St Andrew's church and within 500 m of the Steeple Bumpstead parish boundary. The ground slopes gently downwards to the road between Steeple Bumpstead and Helions Bumpstead which marks its southern boundary, and the site is said by Morant to stand 'in a bottom' (*History and Antiquities of Essex*, 1763).

The site is of ancient occupation and is equated by Morant with the Domesday holding of Aubrey de Vere, whose principal residence lay nearby at Castle Hedingham. The second Domesday holding belonged to Tihel the Breton, from whom the present parish derives its name, and lay at a moated hilltop site some 2 km to the west. De Vere's manor contained 2 hides (ie approximately 240 acres under the plough), and had been held by a certain Wulfwin before the Norman conquest. The Domesday acreage equates with the substantial 343 acres of chiefly arable land that formed Bumpstead Hall farm at the time of the tithe survey in 1841 (ERO D/CT 380). The property continued in the possession of the de Vere Earls of Oxford for five centuries, and the manor of Bumpstead Hall is alternatively known as Earls Bumpstead. Morant refers to an associated deer park, and 19th-century maps show an avenue of large trees leading westwards from the house (of which avenue no trace now remains). The property was eventually sold by the notoriously spendthrift 17th earl in 1580 to William Stubbing, gentleman, whose descendants retained possession at the time of Morant's publication. By the time of the tithe survey it belonged to the trustees of one Richard Salway and was a tenanted farm in the occupation of Thomas Carter. The 'Bumpstead Hall Estate' was purchased in 1887 by D. Gurteen Esquire of the well-known Haverhill cloth manufacturing family (information from an estate plan in the possession of the present owners).

Of the present buildings on the site, only the farmhouse and the two barns appear on the tithe map of 1841 and an identical map of 1812 (ERO D/DQ 1/1). The farmhouse (block 10 in Fig 1) lies at the western end of the farm yards and preserves a mid or late 15th-century jettied and gabled parlour cross-wing in its south-eastern corner. This structure probably adjoined an open hall to the west, but this was rebuilt in the 16th century and its walls raised to their present height in the 18th century. The high quality of the 15th- and 16th-century timber framing is consistent with manorial status, as is that of the westernmost barn (barn 1 below) which originally possessed a crown-post roof and dates from the early 16th century. The easternmost barn was built by a member of the Stubbing family in the early 17th century, albeit recycling medieval timbers, and in response to the present owner's request for appropriate historical names for the two structures, 'Earl's Barn' and 'Stubbing's Barn' might be suggested. The date of the estate's acquisition by Richard Salway is currently unknown, and it is therefore unclear whether the date 1801 and the initials IS (or JS) carved into the corner post of the porch in barn 2 relate to a Stubbing or to Salway.

The parish maps of 1812 and 1841 show the present outlines of the two barns but each is detached and the existing southern yards and shelter sheds are absent. Two long, narrow structures to the north-east of the farmhouse resemble the existing brick sheds (blocks 6-9 below) but do not adjoin each other and occupy slightly different positions; they probably represent an earlier stable and granary of which no trace now remains. The farmhouse has an irregular T-shaped profile that contrasts with its present rectangular form. By the time of the First Edition Ordnance Survey of 1877, the site had been transformed in a manner common to most farm complexes across Essex and Suffolk. With the repeal of the Corn Laws in 1846, the price of grain fell sharply and local farmers were forced to diversify from intensive cereal production to animal husbandry. The development of the railway infrastructure at the same period made distant urban markets available for the first time, and the mid 19th century saw a boom in the region's dairy and beef industry. Instead of selling grain at market prices as hitherto, most farmers now fed their cereals to the cattle in a self-sufficient chain which saw the manure of the new cattle yards returned to fertilise the land. The changes at Bumpstead Hall Farm were entirely typical, with a series of new animal yards, sheds and shelters to the south of the older barns where the latter could offer protection from the weather. Yards of this kind were normally designed to separate dairy and beef cattle, and often included a horse yard with an adjacent stable.

While the 19th-century complex here was unusually sophisticated, with no fewer than six enclosures instead of the usual three, it has been almost entirely destroyed and the existing arrangement is a 20th-century replacement. The brick sheds at the northern edge of the site remain largely intact, although much modified, but of the buildings adjacent to the barns only a single brick wall now survives (incorporated into shelter shed 4). Given the extent of these more recent alterations, the ancillary farm buildings at Bumpstead Hall are of limited historic value when compared to others in the county, although the 20th-century piggery is a fine example of its kind and the two barns are of significance in themselves.

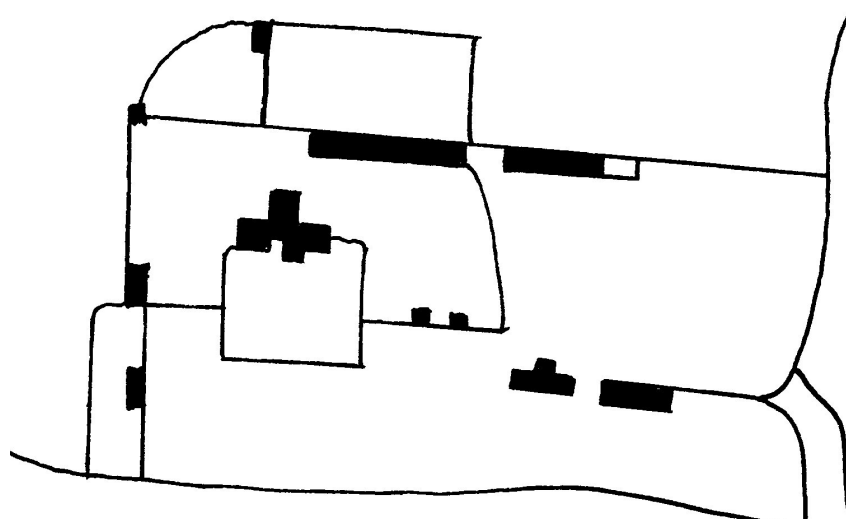

**Illus 1: Bumpstead Hall Farm in 1812 (redrawn from a manuscript map of the parish, ERO D/DQ 1/1).**

Barns 1 and 2 are recognisable in the south-eastern corner, with only barn 1 possessing a porch. The long ranges to the north are similar to those of today but differ in their separation and location and represent earlier structures. The farmhouse has an irregular outline and appears to have possessed a western cross-wing and perhaps a rear stair tower before its extensive mid 19th-century alterations.



**Illus 2: Tithe Map of 1841, ERO D/CT 380.**

An identical situation to that of 1812, with an avenue of trees approaching from the west. The original is aligned eastwards and the outline of barn 1 is interrupted by the farm name.

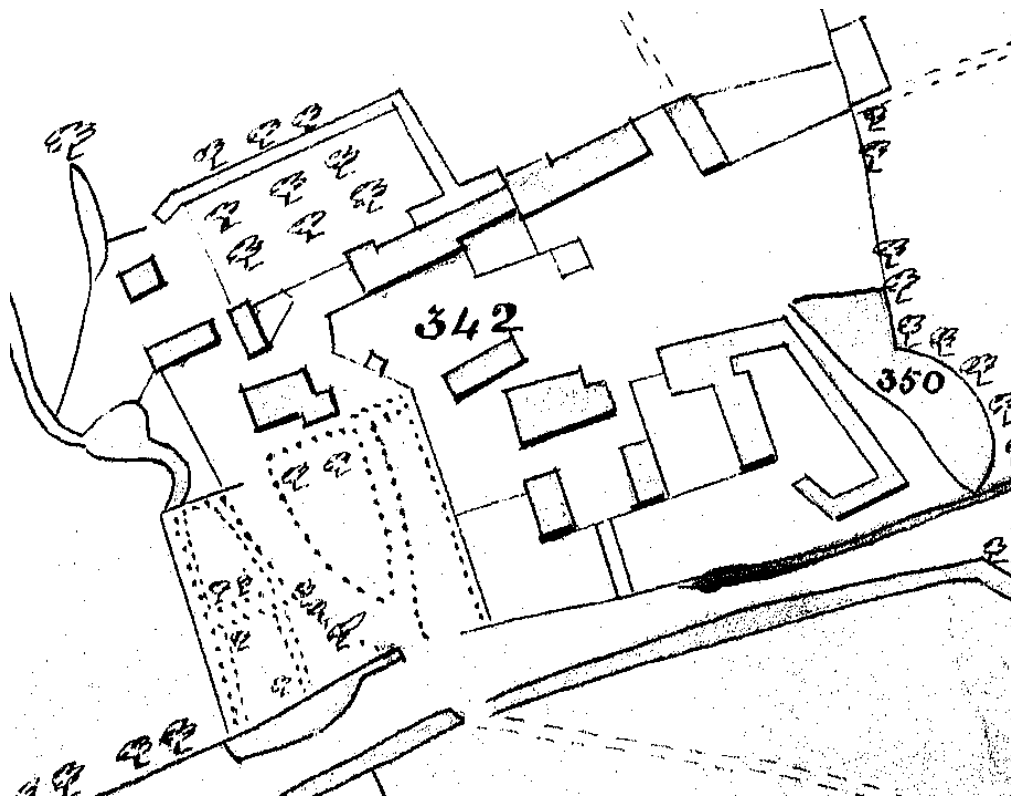

**Illus 3: detail from an undated manuscript estate plan of c 1887 entitled 'Plan of the Bumpstead Hall Estate property of D Gurteen Esq. J.P.', in the possession of the present owners Mr and Mrs Gemmill, who report Gurteen's acquisition in that year.**

The farmhouse (left) has been extended and unified since 1841 and a series of new animal yards built to the south of the barns. This survey is less accurate than the Ordnance Survey below but is included as it shows the western part of the site.

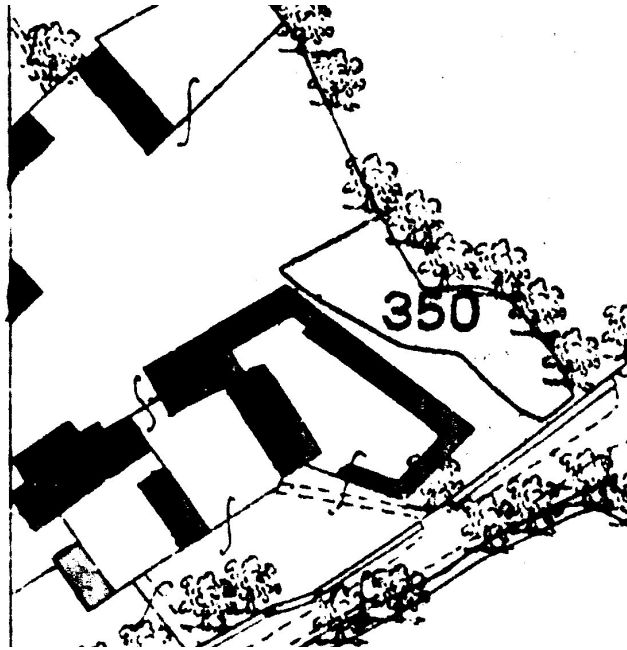

**Illus 4: First Edition 25-inch Ordnance Survey, 1877.**

The new farm buildings are as shown in Illustration 3 above and in more detail on the Second Edition below (Illus 5). The western part of the site lies on a separate sheet which the Essex Record Office does not possess.

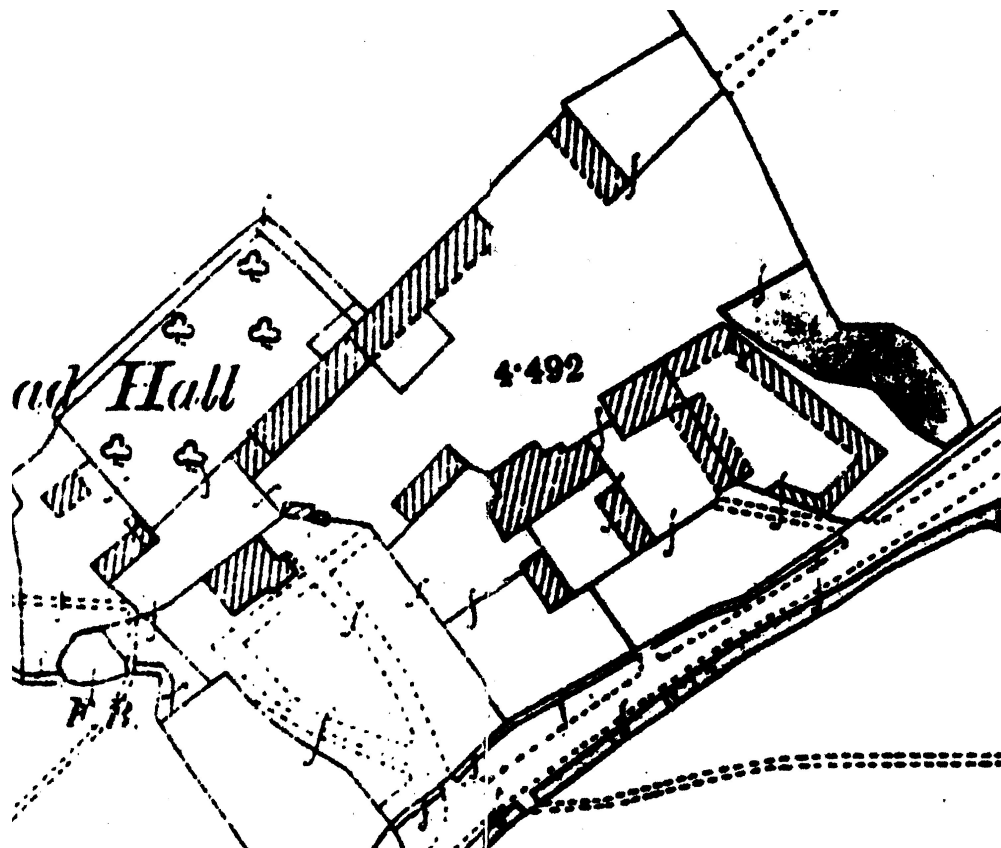

**Illus 5: Second Edition 25-inch Ordnance Survey, 1897 (amalgamated from two sheets).**

Barns 1 and 2 are shown with their present outlines to the north of a series of animal yards with associated sheds and shelters built between 1841 and 1877 (ie the dates of the tithe map and First Edition Ordnance Survey). The irregular yard adjacent to the pond at the eastern edge of the site was formed by three open-sided shelters (as indicated by broken lines) with an enclosed shed to the south, but had been demolished prior to the Third Edition Ordnance Survey of 1921 (Illus 6 below). Its proximity to the pond suggests that this may have been a horse yard and stable. The central yard to the south of barn 2 contains a single open-sided shelter, but this, too, had been demolished and replaced by the existing and much wider shelter shed 3 by 1921. The yard to the south of barn 1 contains two detached and enclosed sheds which had also been demolished by 1921, although the southern gable and western wall of the left-hand shed had been re-used in the open-sided shelter shed 4 which replaced it. The additional structure to the west of barn 1 (known as Cowslip Cottage) is said to have been a dairy or milking parlour adjacent to a cattle yard in the mid 20th century and may have survived from the mid 19th century, but having previously been converted for domestic use was in separate occupation at the time of this survey and was therefore not investigated. The reason for the dramatic and unusual contraction and remodelling of the 19th-century complex so soon after its construction is unclear, but probably relates to the recession in domestic beef production of the early 20th century in response to transatlantic imports. The open-sided shelter or cart-lodge in the north-eastern corner of the site had also vanished by 1921, but the long sheds (blocks 6-9) remain. Note that block 7, which is currently enclosed, is shown as an open-sided continuation of block 6.

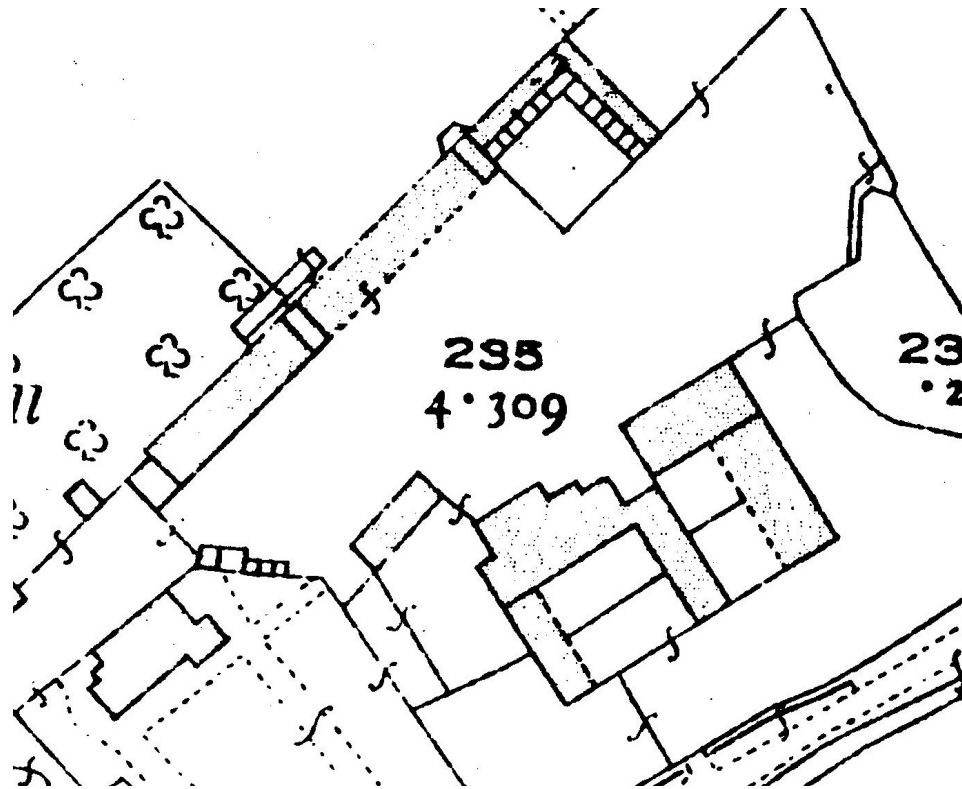

**Illus 6: Third (new) Edition 25-inch Ordnance Survey, 1921.**

The situation shown here is almost identical to the existing layout, but very different to that of 1897 above. Barns 1 and 2 are shown with their present outlines, as are the two open-sided shelter sheds 3 and 4 to the south. An enclosed shed divides the two yards, but this was demolished by the present owners after storm damage in 1987 (it lies between the barns, unlike the earlier structure shown in 1897 which lay to the south of barn 1). This demolished structure is known to have been a stable that was still occupied by two cart-horses known as Daisy and Punch in the 1950s (information from Mrs Gemmill, whose father owned the estate at the time). The enclosed area between the road and stable is believed by Mrs Gemmill to have been a horse yard. The farm had become primarily arable by the mid 20th century, but the sub-divided yards on both sides of this large stable appear from the remaining mangers to have been designed as cattle yards, with the western yard, adjacent to the former dairy (now Cowslip Cottage), housing dairy cattle and the eastern yard beef stock. It is possible, however, that the eastern yard served the stable instead. Mrs Gemmill's father diversified into pig production (at one stage keeping pigs in barn 2), and the new yard shown here in the north-eastern corner of the site contained farrowing houses.

#### **4 Descriptive record**

*The various historic areas of the site's buildings as numbered on the block plan below are described separately in the report, and detailed frame drawings have been prepared for the historic structures proposed for conversion (ie the two timber-framed barns). The following analytical and photographic record makes reference to the two ground-plans (Figs 2 and 6) which associate each storey post with an individual letter. The accompanying figures, which are fully measured and include scales in feet (top) and metres, indicate surviving original timbers with solid lines and reconstruct missing timbers with broken lines where evidence of their positions*

exists. The softwood timbers of the 20th-century alterations have not all been drawn individually, but the modern roof and eaves lines are shown in profile.

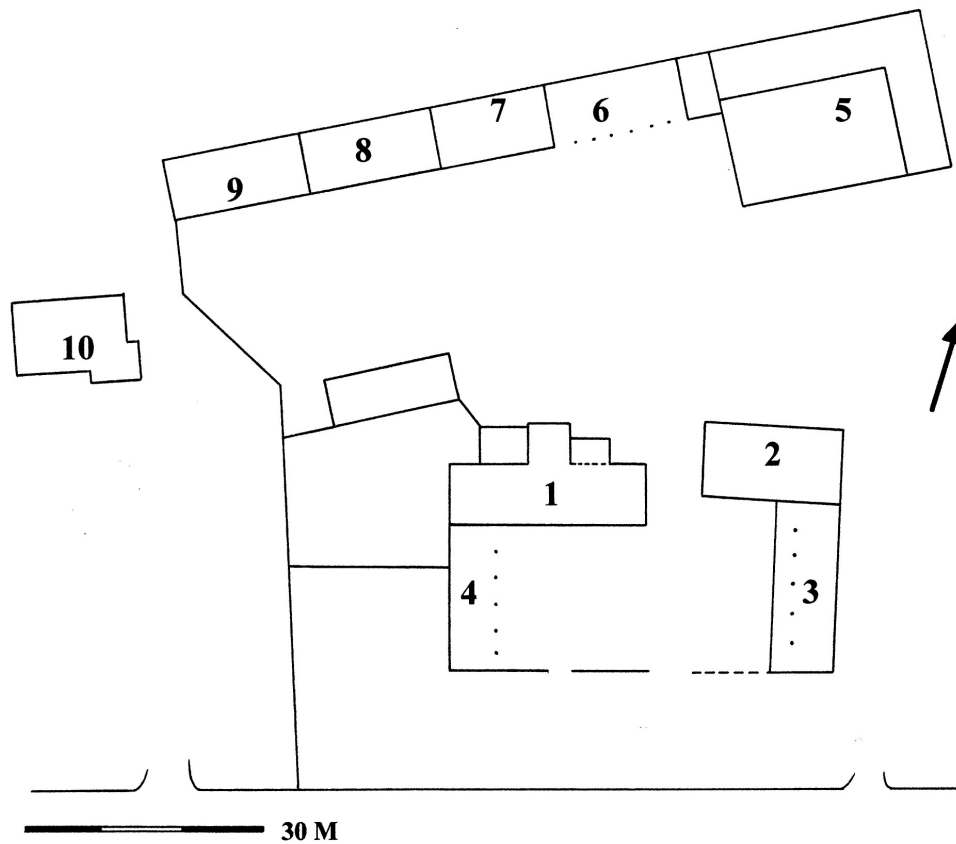

Fig 1 Block plan of farm buildings showing historic areas numbered as follows:

1. Early 16th-century timber-framed barn of five bays with later porch and lean-tos (barn 1).
2. Early 17th-century timber-framed aisled barn of four bays (grade II listed, but described as 16th century).
3. 20th-century timber-framed open-sided shelter shed.
4. 20th-century brick open-sided shelter shed incorporating the wall of a mid 19th-century shed.
5. 20th-century timber-framed piggery incorporating fourteen farrowing houses.
6. Mid 19th-century brick open-sided cart-lodge with attached later shed.
7. Part of 6 above, converted into an enclosed shed in mid 20th century.
8. Mid 19th-century enclosed shed (possibly a machinery shed), built with 9 below.
9. Mid 19th-century enclosed shed containing a granary floor.
10. 15th-century and later farmhouse (included for site context only).



## **Block 1: 16th-century barn (barn 1; Figs 2-5)**

### **Proportions and framing**

The westernmost of the two timber-framed and weather-boarded barns on the site extends to 24.2 m in overall length by 7.5 m in width (79 feet 6 inches by 24 feet 6 inches). The structure contains five bays of approximately 4.5 m (15 feet), but the four outer bays contain unusual central posts which interrupt the mid-rails but are not jowled (unlike the principal posts) and are not associated with original tie-beams (Figs 2-3). Each of these outer bays contains 6 studs both above and below the mid-rails, together with the intermediate posts. The oak timber is of heavy scantling, with each stud measuring approximately 18 cm by 13 cm (7 by 5 inches), and each post 23 cm by 20 (9 inches by 8). The studs are spaced at intervals of approximately 38 cm (15 inches) and were infilled with wattle-and-daub secured by the usual stave notches in the studs and V-grooves in the horizontal rails. There is evidence in the form of empty mortises for externally trenched tension braces at each corner of the external elevations, as shown in Figure 2. The studs and rails are flush externally, and the timber frame would have been exposed both inside and out.

The roof-plates are currently 3.45 m (11 feet 4 inches) above the present ground-level but several storey posts about the concrete floor and any remaining ground sills are buried; it may therefore be assumed that the plates were originally at least 23 cm (9 inches) higher to account for the likely proportions of these sills. The remaining studs are 1.3 m tall between the roof-plates and mid-rails (52 inches) and 1.9 m beneath the mid-rails (76 inches). The principal storey posts are linked by arch-braces to the tie-beams, as shown in Figure 4, and a pegged mortise in the centre of each tie would have held the crown-posts of the missing original roof structure. The gables were identical, as shown in Figure 5, with two intermediate posts dividing the mid-rails, and appear to have been hipped as neither gable tie-beam contains stud mortises in its upper face. The southern roof-plate preserves an original scarf joint of standard edge-halved-and-bridled form (bay U-T in Fig 3).

### **Original layout**

The central bay of the barn (M-N-S-T) has been much altered, as usual, by the insertion of secondary entrances and evidence of the original arrangement is limited. The pattern of mortises in the only remaining roof-plate to the south (T-S in Fig 3) suggests the presence of a wide doorway rising to the eaves of the building; the inner surface of the plate is hidden but its soffit contains no stud mortises above the present door as shown; the western jamb is pegged to both plate and mid-rail and may be an original feature, but the present eastern jamb adjacent to post T appears to be secondary.

Most barns of this period contained a single principal entrance, with only a small doorway in the opposite, rear wall to create a through-draught for winnowing. The northern porch (M-W-X-N) which projects from the central bay is a later addition and the relevant section of roof-plate (M-N) has been removed. Post N is also a later replacement (probably of 1801 as discussed below), but post M appears original yet contains no mortise for a mid-rail extending into the central bay. The absence of such a mid-rail would suggest the presence of an original entrance, in which case the barn would have been designed – most unusually – with two large doors in a manner not normally found until the 18th century. It is possible, however, that post M is also a replacement, and it seems likely that both barns on the site were originally intended to face south towards the nearby road. A horizontal mortise in the roof-plate above the present door jamb adjacent to post S may well have secured the plate of an earlier south-facing porch (the equivalent section of roof-plate adjacent to post T is hidden).

### **Alterations**

The northern porch is an addition of the 17th century which extends to 3.8 m in length by 4.9 m in width (12 feet 6 inches by 16 feet). It consists of small oak studs of approximately 11 cm by 6 (4.5 inches by 2.5) that are interrupted by curved primary braces above the mid-rails in the typical late 17th-century manner as shown in Figure 4 (which superimposes the western side of the porch against truss R-L). The tie-beam of its northern gable (W-X) contains empty stud mortises which are

inconsistent with the present tall entrance door, as are the mid-rail mortises in the two corner posts, but these various timbers may have been re-used from elsewhere.

A lean-to extension lies in the angle of the 17th-century porch and bay N-O, as shown in Figure 2. The original external wall of this bay was entirely removed and a new roof-plate inserted with substantial bolted knee-braces to posts N and O, thereby creating a short aisle. The new outer wall retains its original studs, all of which were re-used from a 15th- or 16th-century building, together with original lath-and-plaster infill which is nailed to the external weather-boarding. A door lies in the eastern gable but this may be a secondary feature. The addition of this aisle or lean-to can probably be dated accurately by an inscription on the western face of post N, which appears to have been renewed at the same time: 'IS / 1801 / July ?18'. The 'I' of this period can also be read as 'J', and may relate to the contemporary owner (Stubbing or Salway). A second lean-to occupies the angle of the porch and bay L-M, but this is currently in separate occupation and was not examined internally. Its outline is shown on the first Edition Ordnance Survey of 1877, but its present fabric appears to date only from the 20th century.

The barn underwent very extensive refurbishment at the beginning of the 20th century (probably when the 19th-century cattle yards to the south were rebuilt around 1920, as discussed above). The roof was entirely renewed with a low-pitched boarded structure of machine-sawn softwood with pre-fabricated king-post trusses, and was probably slated to match the adjoining shelter shed (4 below). The present roof covering is of corrugated iron. The western half of the barn retains much of its original timber work, but has racked towards its gable and was probably close to collapse prior to the refurbishment. The walls in the eastern half of the structure were, in contrast, almost completely rebuilt in softwood leaving barely enough fabric *in situ* to establish its original extent. The western gable (P-V) retains only its tie-beam and corner posts, the empty mortises of which establish that it matched its eastern counterpart as shown in Figure 5. The latter (Q-K) preserves just three original studs along with its two intermediate posts, and its three diagonal braces, which at first glance appear to be medieval, are in fact crudely sawn and nailed additions of the mid 20th century. Only a short length of roof-plate survives in bays V-U and U-T, although, remarkably, the original tie-beam and arch-braces of truss U-O remain despite the absence of post U. The external braces and all wattle-and-daub panels have been removed and much if not all the present tarred weather-boarding is of 20th-century origin. Despite these considerable losses, all four tie-beams and all eight arch-braces remain intact – a feature rarely found in far more complete structures. Additional tie-beams have also been inserted above the intermediate posts in each bay, to which they are secured by bolted knee-braces.

The 20th-century reconstruction incorporated a number of secondary entrances, as indicated in Figure 2, and two high doors that presumably opened onto grain floors of which no trace now remains. The interior has been stripped of any agricultural fixtures or fittings and the barn has most recently served as a machinery and tractor shed with a concrete floor.

### **Date and historic assessment**

Despite the loss of its roof and much of its wall fabric in the 20th century, barn 1 remains an impressive and historically significant structure. The original building is difficult to date with accuracy given the loss of its crown-post roof, but is unlikely to post-date the first quarter of the 16th century and may well be contemporary with the mid to late 15th-century jettied cross-wing of the farmhouse. Crown-posts were quickly replaced by side-purlin structures during the second quarter of the 16th century, and the relative spacing of the studwork and its heavy scantling suggests a date well before their final range. The individual timbers are of unusually large proportions for northern Essex and, at almost 80 feet in length and 24 feet 6 inches in width, it remains among the largest un-aisled barns in the region. Its scale and ostentation are consistent with its manorial status. With the exception, as usual, of its central bay, the original pattern of the building's walls can be reconstructed with precision, and its historic integrity remains intact. Given the rarity of late medieval and early Tudor barns of this scale, and the well-documented nature of the site, the barn retains sufficient historic value, in my view, to justify listing at grade II.

## **Block 2: 17th-century barn (barn 2; Figs 6-12)**

The easternmost of the two timber-framed and weather-boarded barns extends to 18.5 m in overall length by 9.4 m in width (60 feet 9 inches by 31 feet). The structure contains four aisled bays of approximately 4.4 m (14 feet 6 inches), and the 'nave' of each aisled truss is 19 feet wide (inclusive of storey posts). The frame incorporates a high proportion of re-used timber from at least one earlier aisled building of probable early 14th-century date, and the proportions of the individual components varies considerably in consequence. Those wall studs which appear to be primary to the present building are of relatively small scantling at 13 cm by 9 (5 inches by 3.5). The studs are spaced more closely in the southern elevation (F-J) where each bay contains 8 studs, than in the northern elevation (A-E) where there are only seven; similarly, the eastern gable E-J contains eleven studs between its arcade posts where the western gable (F-A) contains only ten, although in other respects the framing is symmetrical. This creates infill panels of 38 cm (15 inches) to the south and west, and 43 cm (17 inches) to the north and east. These panels were infilled by wattle-and-daub as indicated by stave notches in the studs, but only the re-used sections of roof-plate contain the V-grooves which are found throughout barn 1. This differential stud spacing is a common feature in domestic houses, but less so in agricultural structures, and suggests the externally exposed framing was designed to be seen primarily from the road to the south and the approach from Steeple Bumpstead to the east, rather than from the farmhouse to the west. A building contract of 1459 or 1460 for a barn in Bradfield near Bury St Edmunds specifies that the studs of its front gable and the 'farm side' are to be 18 inches apart and those of the rear gable and 'back side', 22 inches (Cambridge University Library Add. 7318 f.9). 'Close studding' was a fashion feature that could significantly affect the cost of a structure and was used for display purposes. Both elevations and gables of barn 2 were also enhanced by symmetrical external stud bracing at each corner and adjacent to the threshing bay (the penultimate western bay), as shown in Figures 7-9.

The lower external walls are encased in late 20th-century concrete to a height of 60 cm, but a section of original ground-sill is exposed in bay J-I. This sill now rests on a tall brick plinth of 18th- or early 19th-century appearance which rises by 1.2 m (4 feet) from the floor of the southern yard; the height of this plinth reflects the slope of the hill and its counterpart to the north, which is hidden by concrete, appears to be approximately 15 cm (6 inches) high. The arcade posts rest on modern concrete pads and there is no evidence of the original aisle sills (which are reconstructed in Fig 9). The external studs rise 1.6 m (63 inches) from the sill to the original roof-plates, and the arcade posts rise 4.1 m (13 feet 6 inches) to the arcade plates. Shore braces link the arcade posts to the aisle ties, and the aisle ties to the missing aisle sills as shown in Figure 9. The tie-beams contain no mortises for crown-posts and the building is likely to have possessed a side-purlin roof. The roof has been entirely replaced with a low-pitched structure of machine-sawn softwood with pre-fabricated king-post trusses, and was probably slated to match shelter shed 4 (which is the only building of the barn complex not to have been re-covered with corrugated iron). The walls were raised to the level of the arcade plates to meet this new roof, which is identical to that of barn 1 and probably also dates from c 1920.

The barn bears numerous carpenters' numerals and marking-out lines, but many relate only to re-used timber. The numerals relating to the present structure are chiselled into the timbers in 17th-century style and are most evident on the arcade posts and tie-beam braces which are primary features of the frame (rather than re-used). At least one arcade brace is numbered in red (ie red ochre) in a manner that was probably commonplace at the time but for which evidence rarely survives. Most of the roof-plates, aisle ties and posts in the external walls are re-used and bear empty lap joints and passing-brace trenches that relate to their previous locations. Figure 9 shows a jowled post with passing-brace to the right (post C) and a lap joint in the left-hand aisle tie. These features are consistent with a late 13th- or early 14th-century date, and may have derived from a single aisled barn of that period. All empty mortises, rafter housings, infill grooves and other joints that are not relevant to the present structure are indicated on the drawings. The extensive re-use

of timber explains the unusual variety of scarf joints in the roof-plates, which include an edge-halved-and-bridled type of typical 15th- and 16th-century form (bay C-D) together with several face-halved-and-bridled scarfs of typical 17th-century form (bays A-B, J-I and I-H). Bay D-E contains a crude edge-halved joint secured by four or more vertical face pegs, and links a re-used section of plate to a primary timber which lacks infill grooves and empty stud mortises (and is therefore original to the present barn). The arcade plates (which are not obviously re-used) contain several scarfs which represent an unusual hybrid between the standard edge-halved-and-bridled and face-halved-and-bladed-forms (normally of the 16th and 17th centuries respectively): these joints are face-halved, but their 'blades' resemble tenons insofar as they do not rise or descend through the full section of the plate. Cecil Hewett illustrated a similar joint in *English historic carpentry* (fig 269, p 268), but with only one 'housed' blade rather than two, and cited an example at Wiggons Barn in Helions Bumpstead.

Wiggons Barn lies at Wiggons Green, 1,100 m immediately north of Bumpstead Hall across open countryside, and has been converted for domestic use (Wiggons Green appears as Wiggons Green on the 1841 tithe map). The structure provides an historically interesting direct parallel for barn 2 at Bumpstead Hall, with identical framing but in three bays rather than four and on a slightly smaller scale. (It extends to 8.4 m in overall width and 14 m in length – 27 feet 6 inches by 46 feet 6 inches.) The frame is more complete, and retains both its original clasped-purlin roof with wind-braces of typical 17th-century appearance and its aisle sills as reconstructed in Figure 9. The arcade-plate scarfs are identical to those of barn 2, as illustrated in Figure 11, but differ from Hewett's drawing as both blades are housed rather than one. This form of scarf is not regarded as common but may well be under-recorded as the housing of its blades would not be recognised under normal circumstances where the top and bottom of a roof-plate is hidden. An example has recently been recorded in an early 17th-century domestic context at Old Thatches, Preston St Mary, Suffolk, now demolished (L Alston for Suffolk Archaeology Unit, September 2007). The description of barn 2 in the Schedule of Listed Buildings describes its scarfs as 'bladed at one end, housed at the other end' and cites Hewett, but is mistaken as both ends are housed. Photographs of Wiggons Barn have been included in the survey for the purposes of historical context.

### **Original layout**

The threshing floor lay in the penultimate bay to the west (B-C-G-H) which has been much altered by secondary entrances. The original roof-plates are interrupted in the northern elevation (bay B-C) by the softwood jambs of the existing entrance which dates only from the 20th century, as shown in Figure 7, and there is no evidence of the 17th-century arrangement. The northern bay (H-G) shown in Figure 8 also contains 20th-century entrances (a door of normal proportions alongside the tall barn doors), but evidence of an original gabled barn door survives in the form of pegged mortises in the outer surface of the arcade plate (shown in Fig 6). These mortises would have secured plates that projected beyond the slope of the aisle roof. The western jamb of the present door pre-dates the 20th-century eastern jamb and is supported by a diagonal brace (Fig 8); a matching eastern brace has been truncated by the 20th-century jamb, suggesting the earlier door was narrower and not central to the bay. The western jamb does not coincide with the arcade-plate mortises, however, and is probably secondary. The non-central arrangement of the mortises indicates that the original entrance possessed a small door alongside the large for use when the latter was closed. The barn at Wiggons Green preserves an identical arrangement, with a non-central principal entrance in its southern elevation and a low door beneath the intact roof-plate of its northern wall. It therefore seems probable that barns 1 and 2 were both designed to face south towards to the Steeple Bumpstead road.

### **Alterations**

The barn was extensively refurbished at the beginning of the 20th century in a similar fashion to barn 1 and the southern shelter sheds (as discussed above). The roof was entirely renewed with a low-pitched structure of machine-sawn softwood with pre-fabricated king-post trusses and its external walls were raised to the level of the arcade plates. The roof is currently covered with corrugated iron but was probably slated to match the shelter shed 4. The original framing is largely intact, although various studs have been renewed in 20th-century softwood and a mid 20th-century sliding door has replaced all the lower-storey framing between the arcade posts of the eastern gable (E-J in Fig 10). The three open trusses retain their key structural components, although several shore braces have been lost, and the arcade-plates and braces are also intact. Several external wall braces survive, albeit some in fragmentary state, but others have been removed as shown in the figures.

The 20th-century reconstruction incorporated upper and lower doorways in the western gable and an upper doorway in the eastern gable, and, as in barn 1, these high doors presumably opened onto grain floors which have since been removed. The interior has been stripped of any agricultural fixtures or fittings, with the exception of a 20th-century iron hay-rack in bay J-I, and the barn is understood to have been converted into pig accommodation in the mid 20th century; the iron sheets that formed the various sties remained on the concrete floor at the time of inspection but were not *in situ*.

### **Date and historic assessment**

Despite the loss of its roof and the raising of its walls in the 20th century, barn 2 remains a largely intact and historically interesting example of an early 17th-century aisled barn. Various elements of the framing suggest a date during the first quarter of the century, or perhaps c 1630, including the chiselled carpenters' numerals, face-halved-and-bladed scarf joints, small stud scantlings and the high, flat-pitched braces of the open trusses. The original roof was almost certainly identical to the clasped-purlin example at Wiggons Barn, which includes sharply cranked braces of typical 17th-century form, and the two structures were probably the work of the same hand. The unusual arcade-plate scarf joints of both barns have no obvious advantage over the more usual forms and would have been more complicated to cut; they may indicate a compromise on the part of a conservative carpenter between the new bladed scarfs of the 17th century and the tenoned examples of the 16th, and certainly represent a hybrid of the two. These scarfs appear in both the arcade and roof-plates at Wiggons, which contains no re-used timber, but only in the 'new' arcade-plates at Bumpstead Hall. The re-used timbers were taken from a barn-like building with passing braces and lap joints in the style of the early 14th century and are of interest in themselves. Although barn 2 is of a more common and utilitarian form than barn 1, it is correctly listed at grade II, although it should be noted that the list description is incorrect in assigning the building to the 16th century and in its analysis of the arcade-plate scarf joints.

### **Block 3: 20th-century shelter shed (eastern)**

Block 3 forms the eastern side of an enclosed yard to the south of barn 2 and is an open-sided shelter shed with an intact hay-rack attached to the wall of the barn at its northern end. It extends to 22.5 m in length by 7.6 m in width (74 feet by 25), although its roof projects by a further 1.7 m (5.5 feet) beyond its arcade posts to provide additional shelter. The arcade posts of the six-bay structure are held in iron shoes. The roof-plates are 2.8 m (9 feet) above the ground, and both the softwood framed, weather-boarded external walls and the king-post roof trusses are consistent with the c 1920 redevelopment of the farm complex as suggested by the map evidence. The roof is currently covered with corrugated iron but was probably formerly slated to match shelter shed 4 opposite.

The hay-rack at the shelter's northern end consists of diamond-section rungs in the usual manner, and is 1.6 m (5 feet 3 inches) above ground-level. Its rungs are largely lacking and a number of horizontal rails have been inserted as a repair. Wooden rail fencing and straw bales bear witness to its most recent use as a sheep

pen, but this shelter was presumably designed for beef stock as opposed to the dairy cattle in the western yard. It is possible, however, particularly given the depth of its overhang, that it operated instead as a horse yard adjacent to the reported central stable shown on the Ordnance Survey of 1921 but now demolished.

#### **Block 4: 20th-century shelter shed (western)**

Block 4 forms the western side of an enclosed yard to the south of barn 1 and is an open-sided shelter shed of six unequal bays. It extends to 17.2 m in length by 5.5 m in width (56.5 feet by 18 feet), and is of identical height and roof construction to shelter 3 on the opposite side of the yard. The roof of king-post trusses retains its original covering of slate. The western wall and southern gable are of brick construction, in contrast to the timber-framed walls of shelter 3, but the western wall contains a straight vertical joint 4.2 m (14 feet) from its northern junction with barn 1; this joint suggests that the wall originally belonged to the detached enclosed shed shown on the Ordnance Surveys of 1877 and 1897 but was extended shortly prior to the Survey of 1921 to form the present shelter.

A good early 20th-century hay-rack and boarded manger extends the entire length of the western wall; the hay-rack is 1.6 m above ground-level, and the lip of the manger 1.2 m. An original doorway at the northern end of the western wall gave access to a yard in front of the brick building which has already been converted for domestic use but which is reported to have been a dairy or milking parlour in the mid 20th century. Despite the presence of a hay-rack, which is more usually associated with horse accommodation, this shelter was evidently built to serve a cattle yard (an identical arrangement is illustrated as fig 3.14 of Paul Barnwell and Colum Giles' *English farmsteads 1750-1914*). The shelter also contains iron hurdles and has most recently been used as a sheep shelter (as indicated by the presence of fleeces in the mangers and sheep droppings on the ground).

#### **Block 5: 20th-century pig yard**

The enclosed yard in the north-eastern corner of the site appears on the Ordnance Survey of 1921 but not that of 1897. Its northern and eastern sides are formed by two softwood-framed ranges of pig-sties from which the individual yards shown in 1921 have been removed. Their roofs are now covered with corrugated iron. Each range extends to 19 m (62 feet) in length and contains seven sties entered by half-hung doors (ie fourteen in all). The sties contain evidence in varying degrees of preservation for a raised, boarded platform upon which the sows were secured, and the three sties at the western end of the northern range also contain small vertical hatches of similar type to the manure holes found in stables. The reason for these hatches, and their absence from the remaining sties (which are otherwise identical), is unclear.

#### **Blocks 6-7: mid 19th-century brick cart-lodge**

The western range of the pig yard adjoins a brick structure with a king-post truss roof covered with treble-tiles that was originally open to the northern yard and extended to an impressive 33 m (110 feet in length). The building appears to be that shown on the 1877 and 1897 Ordnance Surveys and is part of the mid 19th-century redevelopment of the farm. The narrow enclosed office at its eastern end, however, is a later addition which is shown on the 1921 Ordnance Survey and may be contemporary with the adjoining piggery (this extension increased the length of the structure to 36 m or 120 feet). As the treble tiles extend across the junction without interruption, they can be regarded as 20th-century replacements of the original slate. The western half of the building (shown as '7' in Fig 1) was enclosed with concrete blocks in the mid 20th century to form a workshop. The scale of this structure and its location to the rear of a large, open yard suggests that it was designed as a cart-lodge and implement shelter, but its remaining open arcade currently shelters only

bales of hay. The purpose of an apparent enclosed yard at its western end shown on the 1897 Ordnance Survey is uncertain.

### **Blocks 8-9: mid 19th-century enclosed brick sheds**

The brick building at the western end of the farm complex extends to 100 feet in length and contains two large sheds with a narrow shed at its eastern end. This structure pre-dates the adjoining cart-lodge, as indicated by the junction between the two, but is of similar mid 19th-century date. Its roof structure of king-post trusses is covered with its original slate. The narrow store of 10 feet in length at the eastern end is entered from the south and lit by a window facing a paddock to the north. The southern entrance of the adjacent shed is provided by a pair of central wide doors, and the interior lit by two windows in each elevation. The western shed (9) reflects the same pattern, but has a single entrance door and contains a granary floor with vertically hinged side-doors in the manner of a stable hay-loft. This building is known to have operated as a grain and feed store in the mid 20th century, and the granary floor is probably an original feature. The two sheds are linked by an internal door which bears pencil inscriptions noting grain types, such as tares, winter wheat, barley and peas, together with dates in August 1978. The central shed housed a feed mill and crusher in the mid 20th century. Both sheds contain central apertures in their rear, northern elevations in the manner of low windows, and these were presumably designed to accommodate belt drives for machinery linked to engines in the northern paddock, which probably operated as a stack yard. With the exception of the granary floor, these brick sheds have been stripped of agricultural fixtures and fittings and have been used most recently for general domestic storage.

## **5 Frame survey for barns 1 and 2 (Figs 2-12)**

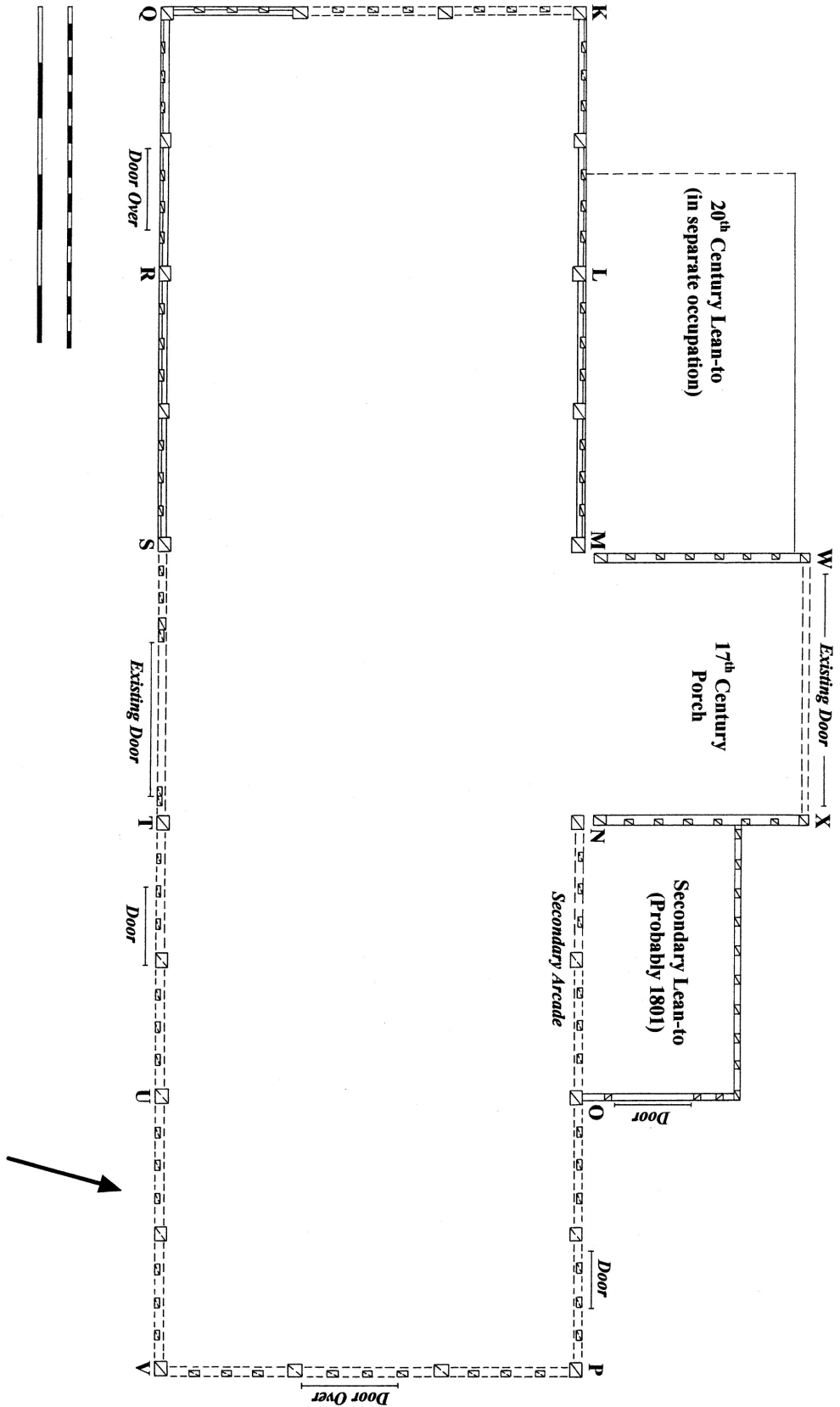

Fig 2 Barn 1: ground-plan.



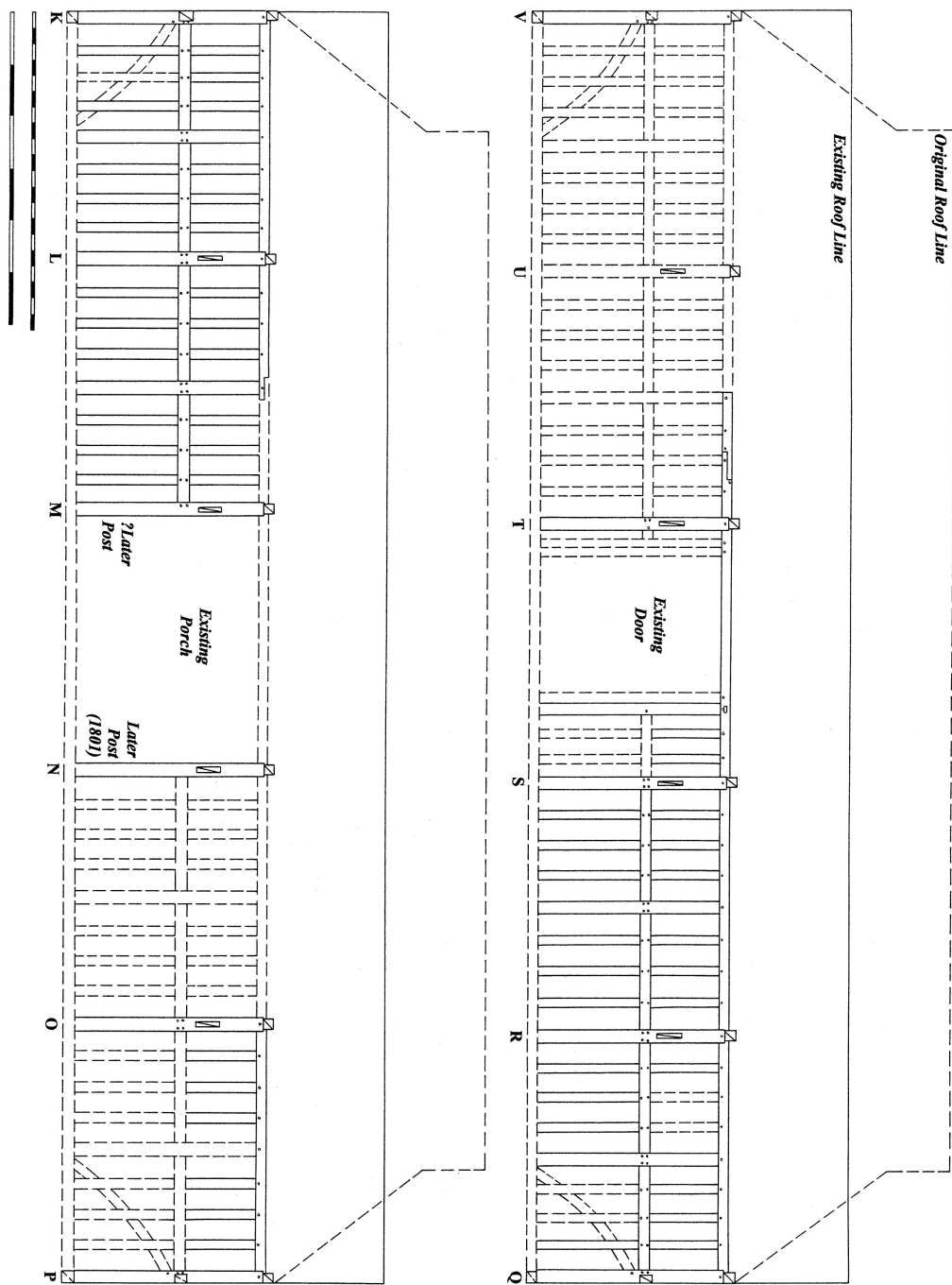

Fig 3 Barn 1: southern internal elevation V-Q (top), and northern internal elevation K-P (bottom).

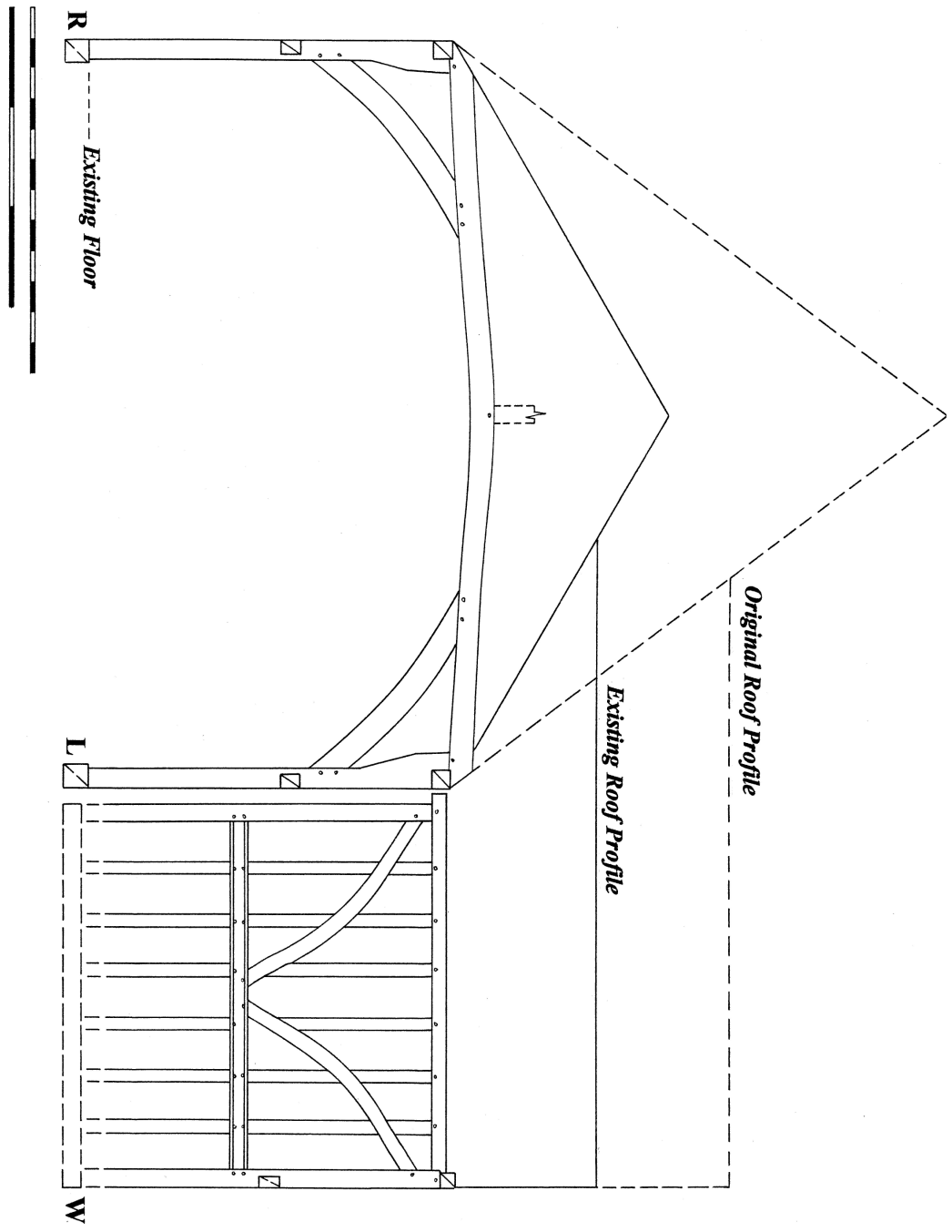

Fig 4 Barn 1: open truss R-L from east with internal elevation M-W of porch.

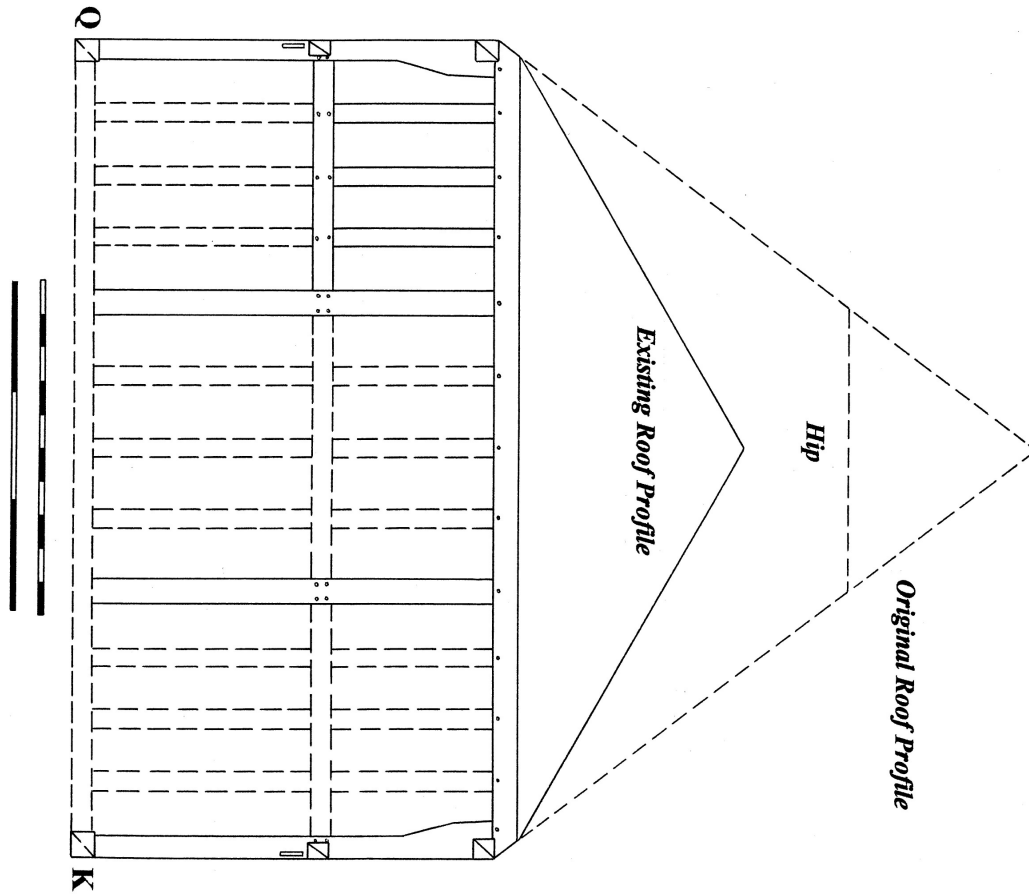

Fig 5 Barn 1: internal elevation of western gable Q-K (eastern gable P-V was originally identical).

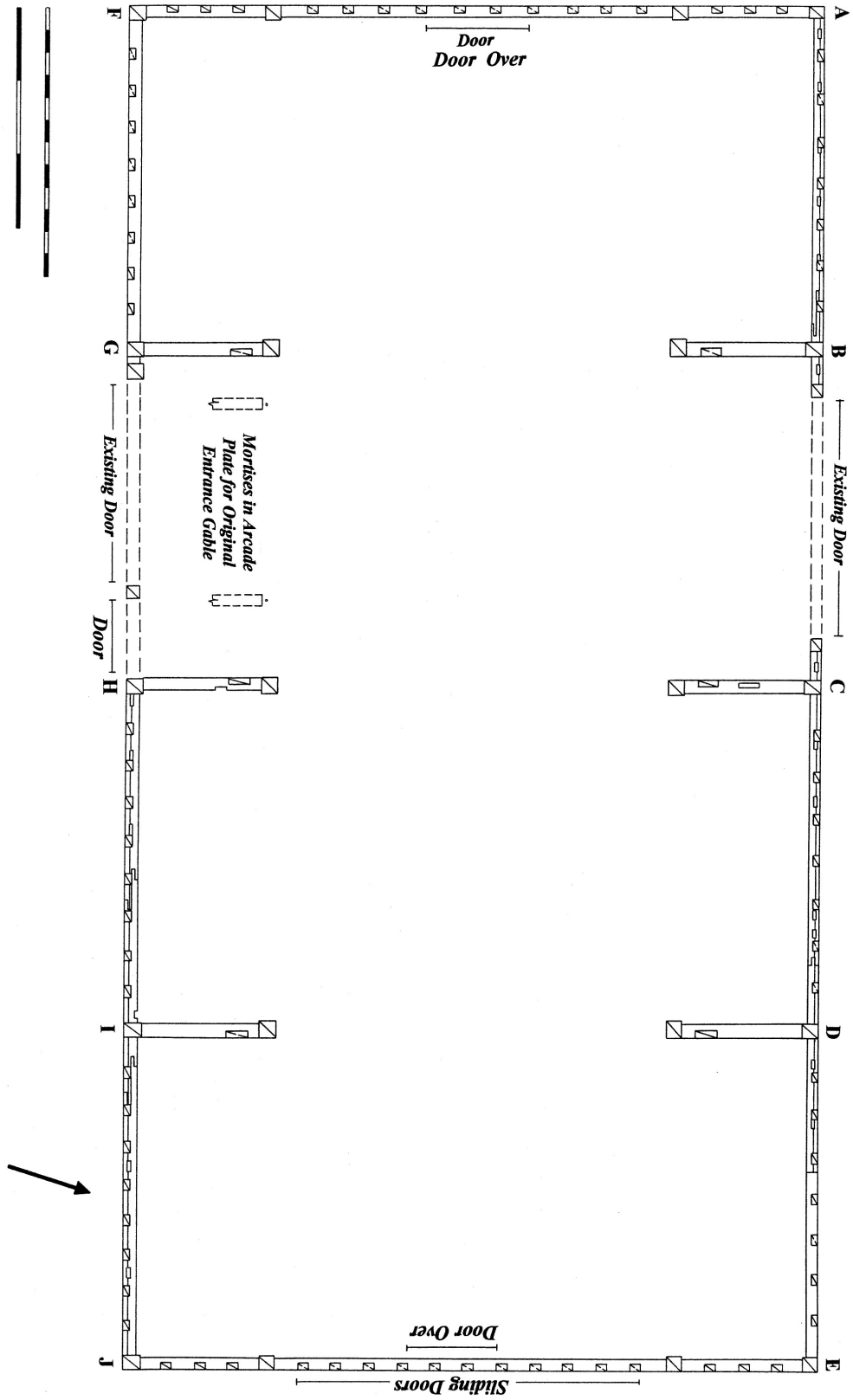

Fig 6 Barn 2: ground-plan.

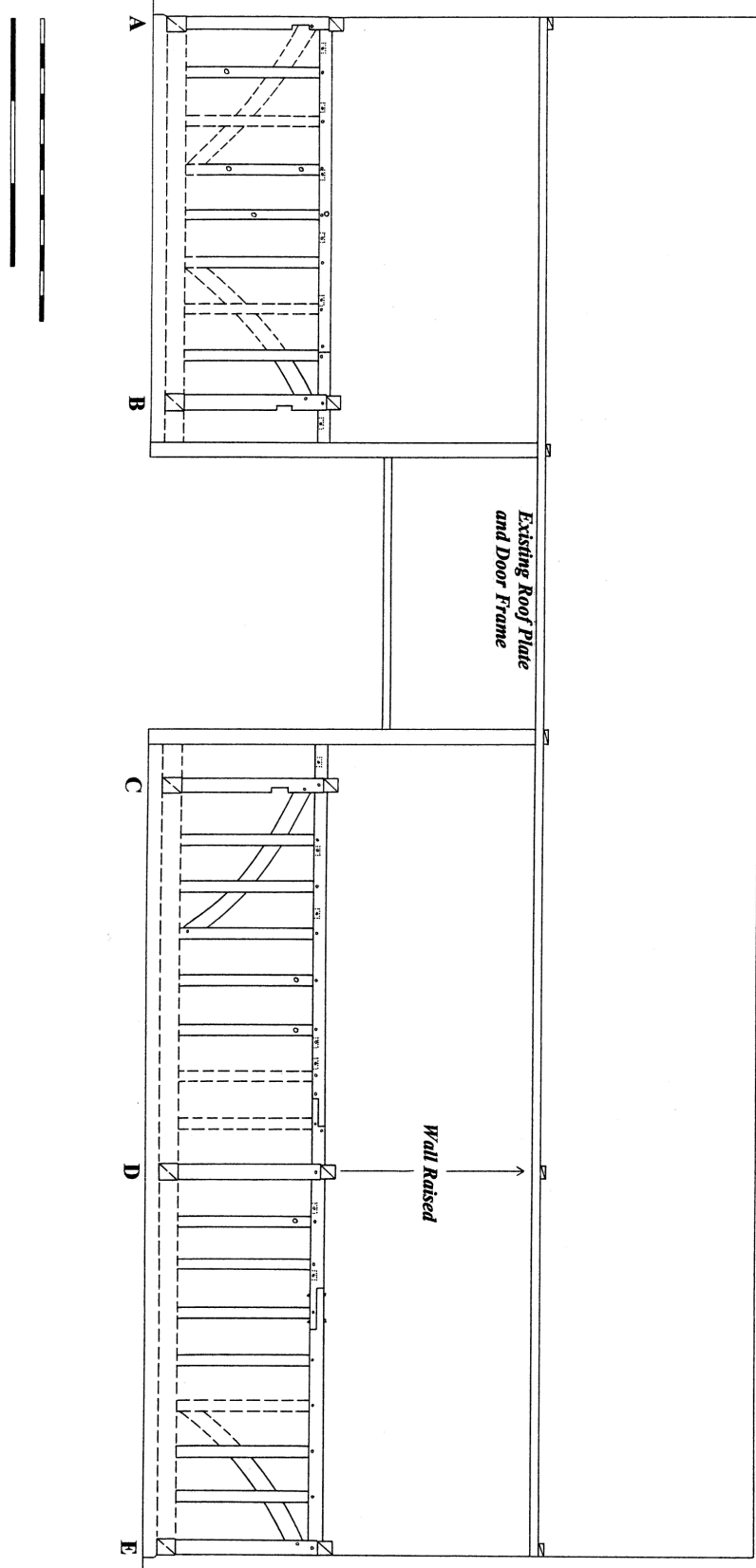

Fig 7 Barn 2: internal elevation of northern wall A-E.

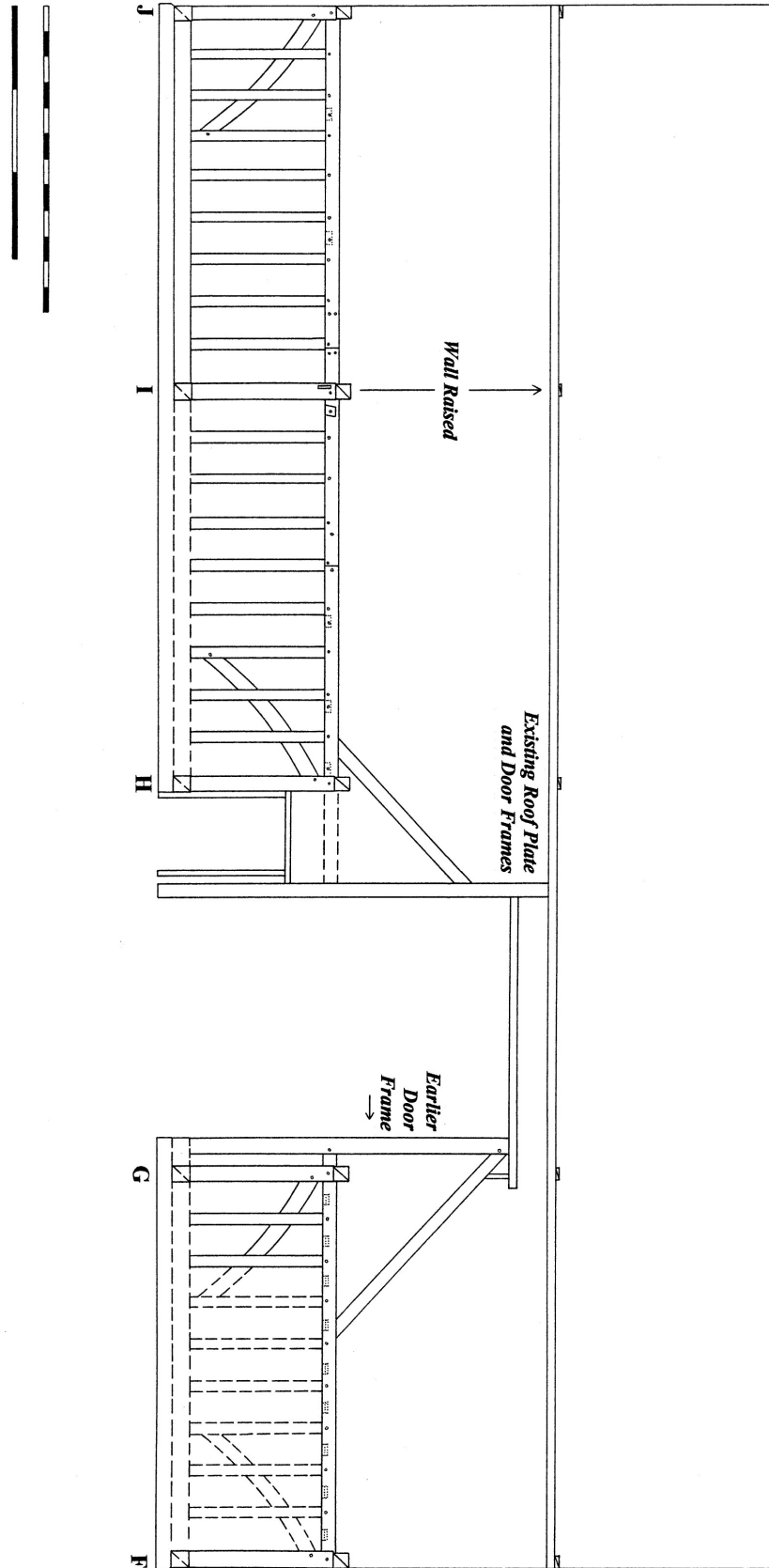

Fig 8 Barn 2: internal elevation of southern wall J-F.

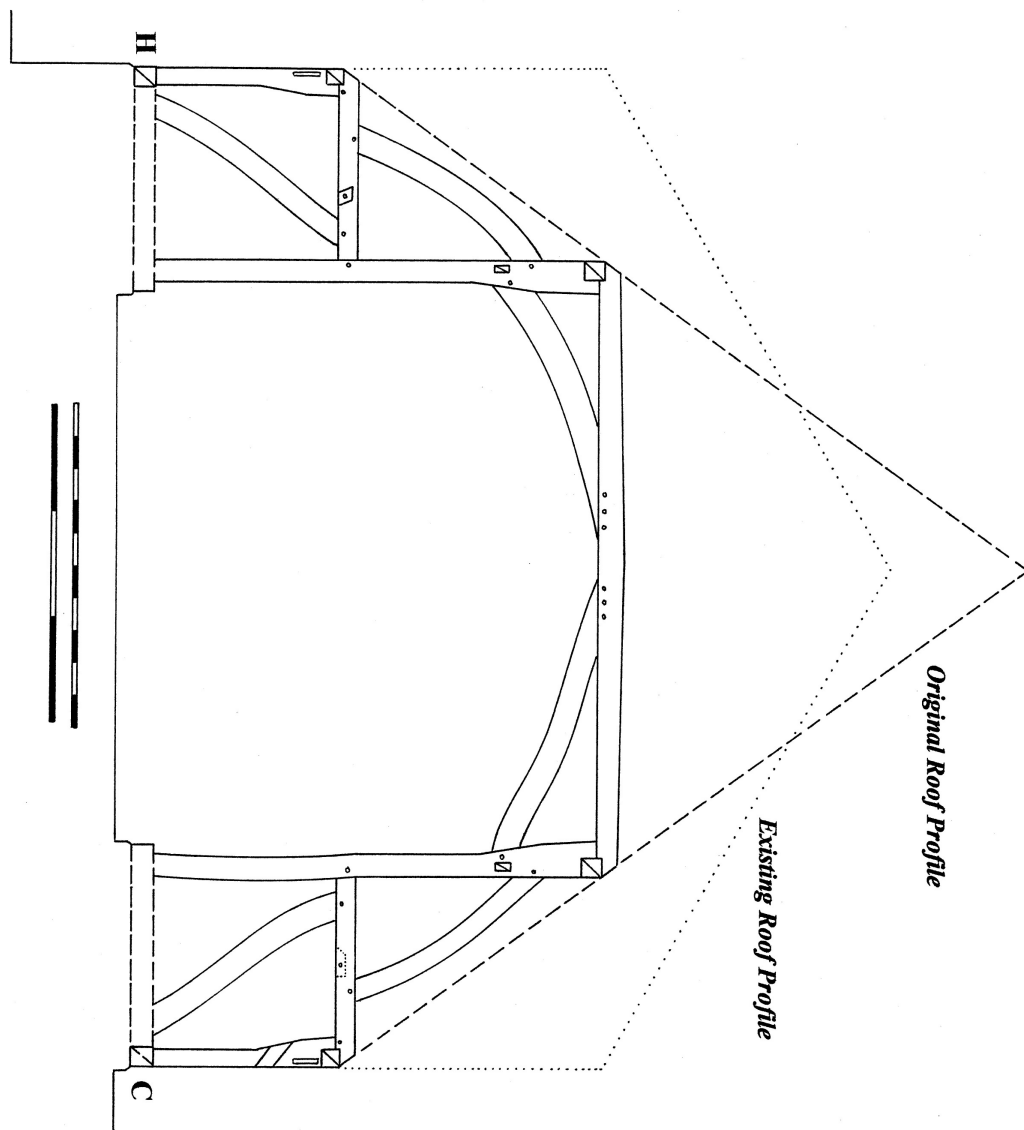

Fig 9 Barn 2: open truss H-C from east.

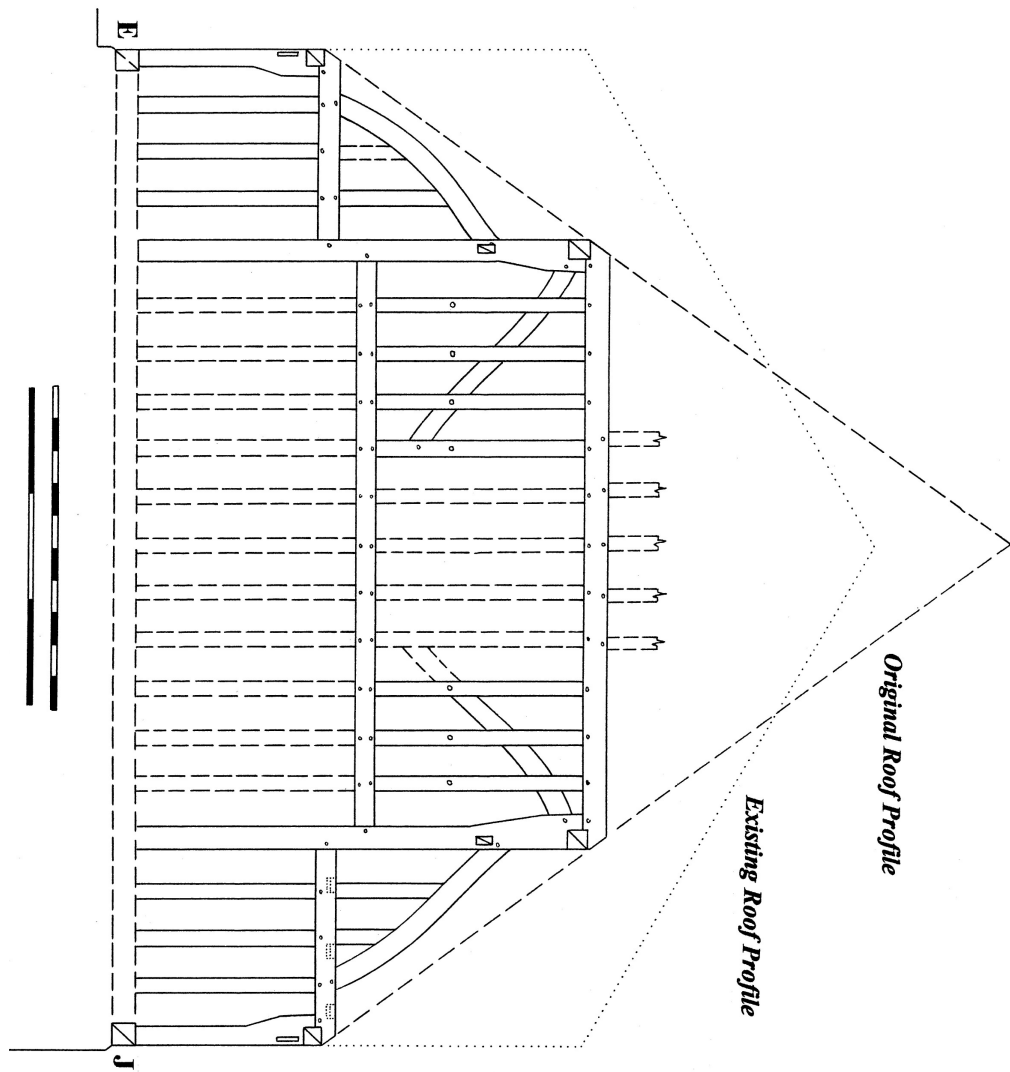

Fig 10 Barn 2: internal elevation of eastern gable E-J (western gable F-A originally contained only ten studs between its arcade posts but was otherwise identical).



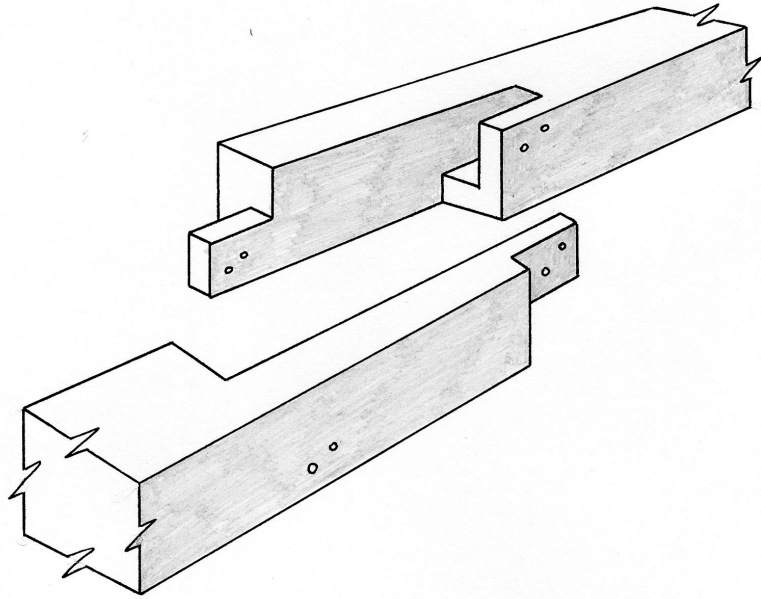
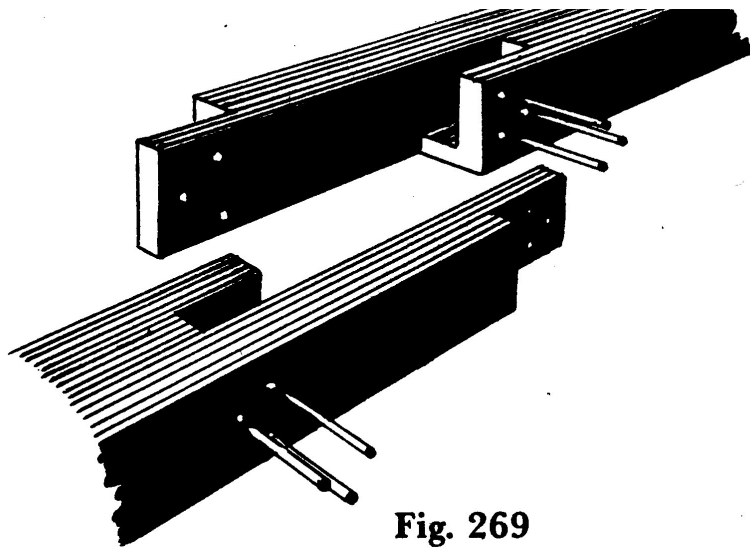

Fig 11 Barn 2: detail of arcade-plate scarf joint.



**Fig. 269**

Fig 12 Barn 2: similar scarf at Rookwood Hall Granary, Abbess Roding, from figure 269 of Cecil Hewett's *English historic carpentry* (Phillimore 1980).

## Appendix 1: selected photographs



A1.1 Barn 1: exterior from south, showing elevation Q-V.



A1.2 Barn 1: exterior from north, showing later porch and lean-to.





A1.3 Barn 1: general internal view from north-east.



A1.4 Barn 1: general internal view from north-west, showing 1801 lean-to left.





A1.5 Barn 1: internal bay R-Q showing largely original framing and later door above mid-rail (western gable to right).



A1.6 Barn 1: detail of carving to western face of post N: 'IS 1801 July 18'.





A1.7 Barn 2: exterior from north, showing elevation E-A.



A1.8 Barn 2: general view of interior from east.





A1.9 Barn 2: interior of gable E-I showing late 20th-century sliding doors below mid-rail with early 20th-century door above.



A1.10 Barn 2: detail of empty lap joint in re-used aisle tie to post I.





A1.11 Barn 2: detail of face-halved scarf with housed blades in bay I-H.



A1.12 Barn 2: detail of original studwork in bay C-D showing infill notches, external brace and passing brace trench in re-used post C to left.





A1.13 Wiggons Barn: original clasped-purlin roof (included for comparison).



A1.14 Shelter 3: exterior from south-west with barn 2 to left.





A1.15 Shelter 3: interior from south, looking towards hay-rack attached to barn 2.



A1.16 Shelter 3: detail of hay-rack from south-east showing secondary rack within.





A1.17 Shelter 4: exterior from yard to east with old sack drying frames in foreground.



A1.18 Shelter 4: interior of southern gable showing king-post roof, manger and hay-rack.





A1.19 Piggery 5: exterior of yard from south showing doors to fourteen sties.



A1.20 Piggery 5: front internal wall of sty in eastern wing, with sow bed to left.





A1.21 Shelter 6: exterior from south, with later enclosed shed (7) to left.



A1.22 Southern exteriors of sheds 9 and 8 from east, showing shed (7) to right.





A1.23 Shed 9: interior from south-west, showing door to shed 8 and granary floor.



A1.24 Farmhouse 10: exterior from south, showing 15th-century parlour wing to right.

## Appendix 2

### Photographic record (images on the accompanying CD)

#### Description of photographs in Appendix 2

- 1 General view of site from east, showing farm complex to right and adjacent highway leading from Steeple Bumpstead towards Helions Bumpstead to left.
- 2 General view of site from south-east, showing existing entrance to farm complex.
- 3 General view from south-east, showing southern yards and highway in foreground.
- 4 General view from west, showing yards to left and highway to right.
- 5 General view from south, showing yards and barns (barn 1 to left, barn 2 to right).
- 6 General view of barn 1 (right) and barn 2 from west.
- 7 Barn 1: exterior and yard from south-east.
- 8 Barn 1: exterior from east, showing gable V-P with shelter 4 left (taken from within shelter 3).
- 9 Barn 1: exterior from south-west, showing gable K-Q with shelter 4 to right.
- 10 Barn 1: exterior from south, showing elevation Q-V.
- 11 Barn 1: exterior from north, showing elevation P-K.
- 12 Barn 1: exterior from north-east, showing later porch and lean-to.
- 13 Barn 1: interior of barn viewed from porch entrance to north.
- 14 Barn 1: interior of porch M-W-K-N from body of barn to south.
- 15 Barn 1: internal elevation of porch K-L.
- 16 Barn 1: internal elevation of porch M-W.
- 17 Barn 1: detail of primary bracing in porch elevation M-W.
- 18 Barn 1: general internal view from north-east.
- 19 Barn 1: general internal view from north-west, showing 1801 lean-to left.
- 20 Barn 1: general internal view, showing 20th-century king-post roof from west.
- 21 Barn 1: internal gable P-V, showing 20th-century wall frame but original posts and tie-beam.
- 22 Barn 1: internal bay V-U, showing original tie and arch-brace right.
- 23 Barn 1: internal bay U-T, showing 20th-century door.
- 24 Barn 1: detail of bay U-T, showing truncated roof-plate and scarf.
- 25 Barn 1: detail of edge-halved-and-bridled scarf in bay U-T and stud mortises.
- 26 Barn 1: internal bay T-S, showing 20th-century door.
- 27 Barn 1: internal bay S-R, showing original framing with later intermediate tie and knee.
- 28 Barn 1: internal bay R-Q, showing largely original framing and later door above mid-rail (western gable to right).
- 29 Barn 1: interior of gable Q-K, showing 20th-century braces and studs.
- 30 Barn 1: detail of gable Q-R, showing original studs and posts.
- 31 Barn 1: internal bay K-L, showing largely intact framing.
- 32 Barn 1: internal bay L-M, showing largely intact framing.
- 33 Barn 1: replaced post N from west, bearing incised date above plinth.
- 34 Barn 1: detail of carving to western face of post N ('IS 1801 July 18').
- 35 Barn 1: internal bay N-O, showing later roof-plate and lean-to.
- 36 Barn 1: interior of later lean-to from east, showing 1801 dated post N left.
- 37 Barn 1: interior of later lean-to from west, showing post O to right.
- 38 Barn 1: detail of re-used studs and plaster to northern wall of later lean-to.
- 39 Barn 1: internal bay O-P, showing intact upper studs.
- 40 Barn 1: interior of roof from east, showing intact tie-beams and arch-braces.
- 41 General view from north-east, showing barn 2 (left) and barn 1.

- 42 General view of barn 1 (right) and barn 2 from north, showing relative proximity of gables.
- 43 General view of northern yard from east, showing barns to left.
- 44 Barn 2: exterior and yard from south, showing shelter 3 right.
- 45 Barn 2: exterior from south, showing entrance doors.
- 46 Barn 2: exterior from west, showing gable A-F.
- 47 Barn 2: exterior from north, showing elevation E-A.
- 48 Barn 2: exterior from north, showing detail of entrance doors.
- 49 Barn 2: exterior from north, showing detail of door pintle and hinge.
- 50 Barn 2: exterior from north, showing detail of tarred boarding.
- 51 Barn 2 from east, showing shelter 3 to left.
- 52 Barn 2: exterior from east, showing gable J-E with 20th-century sliding doors.
- 53 Barn 2: general view of interior from east.
- 54 Barn 2: interior view from east, showing 20th-century king-post roof.
- 55 Barn 2: interior of gable E-I, showing late 20th-century sliding doors below mid-rail with early 20th-century door above.
- 56 Barn 2: internal bay J-I with 20th-century iron hay-rack.
- 57 Barn 2: detail of iron hay-rack in bay J-I from north-east.
- 58 Barn 2: detail of standard face-halved-and-bladed scarf in bay J-I.
- 59 Barn 2: re-used aisle tie-beam at post I, showing empty lap joint.
- 60 Barn 2: detail of empty lap joint in re-used aisle tie to post I.
- 61 Barn 2: detail of chiselled carpenters' numerals to arcade post I.
- 62 Barn 2: internal bay I-H, showing scarf in arcade plate top left.
- 63 Barn 2: detail of face-halved scarf with housed blades in bay I-H.
- 64 Barn 2: internal bay H-G, showing southern doors.
- 65 Barn 2: detail of housed blade of scarf in bay H-G.
- 66 Barn 2: internal bay G-F.
- 67 Barn 2: interior of gable F-A, showing upper and lower secondary doors.
- 68 Barn 2: interior – detail of lower door in gable F-A.
- 69 Barn 2: internal bay A-B, showing part of original brace to right.
- 70 Barn 2: detail of arcade bracing in bay A-B with 20th-century framing in rear.
- 71 Barn 2: internal bay B-C, showing northern entrance doors.
- 72 Barn 2: detail of re-used post B from east, showing empty passing-brace trench.
- 73 Barn 2: internal bay C-D, showing original wall brace to left.
- 74 Barn 2: detail of re-used post C from east, showing empty passing-brace trench.
- 75 Barn 2: detail of original studwork in bay C-D, showing infill notches.
- 76 Barn 2: arcade post C from east, showing configuration of shore-braces.
- 77 Barn 2: detail of redde carpenters' numeral to arcade post C from east.
- 78 Barn 2: internal bay D-E with original brace to right.
- 79 Barn 2: detail of edge halved and face pegged scarf in bay D-E.
- 80 Wiggons Barn, Wiggons Green, Helions Bumpstead: open truss (included for comparison).
- 81 Wiggons Barn: arcade plate scarf with housed blades (included for comparison).
- 82 Wiggons Barn: clasped purlin roof (included for comparison).
- 83 Shelter 3: exterior from south-west with barn 2 to left.
- 84 Shelter 3: interior from south, looking towards hay-rack attached to barn 2.
- 85 Shelter 3: detail of roof overhang from south.
- 86 Shelter 3: detail of iron shoe to arcade post.
- 87 Shelter 3: detail of arcade post from south.
- 88 Shelter 3: detail of king-post roof.
- 89 Shelter 3: interior from north, showing recent hurdle fencing.
- 90 Shelter 3: interior of southern gable from north.

- 91 Shelter 3: interior from south, showing hay-rack against wall of barn 2.
- 92 Shelter 3: detail of hay-rack from south-west.
- 93 Shelter 3: detail of hay-rack from south-east, showing secondary rack within.
- 94 Shelter 3: detail of wooden hay-rack bars.
- 95 Shelter 3: northern gable, showing brick plinth of barn 2.
- 96 Shelter 4: exterior from yard to east with old sack drying frames in foreground.
- 97 Shelter 4: exterior from south-east, showing yard gate to left.
- 98 Shelter 4: exterior from south-west, showing brick construction.
- 99 Shelter 4: exterior from south-east, showing arcade posts.
- 100 Shelter 4: detail of iron shoe to arcade post.
- 101 Shelter 4: interior of southern gable, showing king-post roof, manger and hay-rack.
- 102 Shelter 4: interior from south, showing barns and yards to east.
- 103 Shelter 4: interior from north, showing hay-racks and mangers to western wall.
- 104 Shelter 4: manger against southern gable.
- 105 Shelter 4: manger to south of centre.
- 106 Shelter 4: manger to north of centre.
- 107 Shelter 4: manger towards northern gable.
- 108 Shelter 4: detail showing boarded manger construction from north.
- 109 Shelter 4: detail showing boarded manger against southern gable.
- 110 Shelter 4: detail showing hay-rack from north.
- 111 Shelter 4: detail showing hay-rack construction.
- 112 Piggery 5: pig yard in north-eastern corner of site seen from south.
- 113 Piggery 5: exterior from south, showing doors to fourteen sties.
- 114 Piggery 5: exterior of northern range from south.
- 115 Piggery 5: exterior of eastern range from west.
- 116 Piggery 5: exterior of eastern range from south-east.
- 117 Piggery 5: exterior from west, showing hatch doors to the two westernmost sties.
- 118 Piggery 5: exterior of westernmost sties from south (both with rear hatches).
- 119 Piggery 5: internal rear wall of westernmost sty from south, showing hatch to right.
- 120 Piggery 5: detail of rear hatch in westernmost sty.
- 121 Piggery 5: internal front wall of westernmost sty from north.
- 122 Piggery 5: interior of sty in eastern wing – rear eastern wall showing sow bed.
- 123 Piggery 5: detail of boarded sow bed in eastern wing.
- 124 Piggery 5: front internal wall of sty in eastern wing, with sow bed to left.
- 125 Shelter 6: exterior from south-west with piggery 5 in rear.
- 126 Shelter 6: exterior from south, with later enclosed shed 7 to left.
- 127 Shelter 6: interior from south-west, showing king-post roof.
- 128 Shelter 6: interior from east, showing open arcade.
- 129 Shelter 6: exterior of enclosed shed at eastern end seen from south.
- 130 Shelter 6: interior of enclosed shed from north.
- 131 Shelter 6: interior of enclosed shed from south.
- 132 Shelter 6: exterior of rear wall from north-east.
- 133 Shelter 6: northern exterior of enclosed shed with straight masonry joint to right.
- 134 General view of sheds 9, 8 and 7 from east, showing shelter 6 to right.
- 135 Shed 7: exterior from south.
- 136 Shed 7: junction with shelter 6 from south-east.
- 137 Shed 7: exterior from north showing continuous junction with shelter 6 to left.
- 138 Southern exteriors of sheds 9 and 8 from east, showing shed 7 to right.



- 139 Door to enclosed shed at eastern end of shed 8 from south with shed 7 to right.
- 140 Shed 8: interior of enclosed shed at eastern end viewed from south.
- 141 Shed 8: exterior from south-west, showing sliding entrance doors.
- 142 Shed 8: interior from west, showing sliding entrance doors to right.
- 143 Shed 8: interior from east, showing king-post roof and door to shed 9.
- 144 Shed 8: exterior from north, showing shed 9 to right.
- 145 Shed 8: exterior from north, showing junction with shed 7 to left.
- 146 Shed 9: exterior from south-east, showing entrance door to right.
- 147 Shed 9: exterior from south, showing entrance door to left.
- 148 Shed 9: interior from south-west, showing door to shed 8 and granary floor.
- 149 Shed 9: interior, showing door to shed 8 bearing graffiti.
- 150 Shed 9: detail of graffiti to internal door noting grain types.
- 151 Shed 9: interior from east, showing granary floor.
- 152 Shed 9: interior from east, showing access to granary floor.
- 153 Shed 9: interior of granary floor, showing hinged flaps along rear wall.
- 154 Exterior of sheds 8 and 9 from north-east, showing farmhouse 10 in rear.
- 155 Farmhouse 10: exterior from south, showing 15th-century parlour wing to right.
- 156 Farmhouse 10: jettied parlour wing from south with site of rebuilt medieval hall to left.



**Colchester Archaeological Trust**

12 Lexden Road,  
Colchester,  
Essex CO3 3NF

tel.: (01206) 541051  
(01206) 500124  
email: [archaeologists@catuk.org](mailto:archaeologists@catuk.org)

Checked by: *Philip Crummy*  
Date: 14.11.07

*Adams c:/reports07/helions bumpstead/revised/report443final.doc*

**Essex Historic Environment Record/  
Essex Archaeology and History**

**Summary sheet**

<b>Site address:</b> Bumpstead Hall Farm, Helions Bumpstead, Essex	
<b>Parish:</b> Helions Bumpstead	<b>District:</b> Braintree
<b>NGR:</b> TL 66266 41202	<b>Site code:</b> HBBH 07
<b>Type of work:</b> Building survey	<b>Site director/group:</b> Colchester Archaeological Trust
<b>Date of work:</b> October 2007	<b>Size of area investigated:</b>
<b>Location of finds/curating museum:</b>	<b>Funding source:</b>
<b>Further seasons anticipated?</b> No	<b>Related EHER nos:</b>
<b>Final report:</b> CAT Report 443 and summary in <i>EAH</i>	
<b>Periods represented:</b> ?13th, 14th-20th centuries	
<p><b>Summary of fieldwork results:</b></p> <p><i>Bumpstead Hall occupies the site of a medieval manor of the same name, otherwise known as Earls Bumpstead. The present farmhouse was much altered during the mid 19th century, but preserves a well-framed mid to late 15th-century jettied parlour cross-wing and a 16th-century floored hall.</i></p> <p><i>Of the several farm buildings shown on maps of 1812 and 1841, only two substantial barns survived a major mid 19th-century reconstruction which saw the addition of various cattle yards, shelters and sheds to the south of the barns and a range of brick sheds to the north. A second major refurbishment of the early 20th century saw the demolition of almost all the mid 19th-century buildings to the south and their replacement with a new stable and a pair of open-sided shelter sheds. The 20th-century shelters still survive, and preserve good boarded cattle mangers and hay-racks, but the stable was demolished after the storm of 1987. The northern brick sheds of the mid 19th century still remain, albeit much altered, as does an unusually large enclosure of early 20th-century pig-sties. In the light of the 20th-century demolitions, the ancillary farm buildings are not of particular historic significance when compared with others in the region.</i></p> <p><i>The two timber-framed and weather-boarded barns remain fine examples of the early 16th and early 17th centuries respectively, despite extensive reconstruction and the replacement of both roofs in the early 20th century. The western barn (barn 1) is the older of the two and was a particularly expensive and ostentatious structure when first built, but its merits are now less obvious than those of its neighbour and it is not listed (despite the retention of its original tie-beam braces). This barn extended to 24.2 m in length by 7.5 in width (79 feet 6 inches by 24 feet 6 inches) and contained five bays with a central southern entrance,</i></p>	

*although a secondary porch of the late 17th century now projects to the north. Each of the four outer bays contains an unusual intermediate post, and the original roof, now lost, was of crown-post construction. A lean-to addition to the north can probably be dated to 1801 by an inscription on an associated storey post. This building remains a fine late-medieval barn of considerable structural and historic interest that pre-dates the sale of the property by the Earls of Oxford.*

*The later of the two barns (barn 2) lies to the east of the site and dates from the early 17th century, although its grade II listing wrongly ascribes it to the 16th century. This building consists of four aisled bays and extends to 18.5 m in overall length by 9.4 m in width (60 feet 9 inches by 31 feet). There is evidence of an original southern entrance in the penultimate western bay. Like barn 1, its roof (originally of side-purlin construction) and many of its wall studs were replaced at the beginning of the 20th century; the height of its external walls was also raised, thereby completely transforming its external appearance. The framing of the original walls consists largely of re-used timbers that are of interest in themselves as many derive from an early 14th-century aisled structure which possessed lap joints and passing braces, although it is now impossible to reconstruct its precise form.*

***Previous summaries/reports:*** None

***Author of summary:***  
Leigh Alston

***Date of summary:***  
November 2007